The Development of Agarwood Chopper Machines to Increase Agarwood Farmers' Efficiency During the Pandemic

Ahmad Mursyidun Nidhom^{1*}, Gres Dyah Kusuma Ningrum², Azhar Ahmad Smaragdina³

¹Universitas Negeri Malang; Semarng Street Number 6

^{1,2,3} Informatics Engineering Education, Faculty of Engineering, State University of Malang
e-mail: *¹ nidhom.ft@um.ac.id

Abstrak

Partner Village Development (PDM) State University of Malang is an activity that aims to develop regional superior potential to improve the economy of partner villages, develop science and technology and increase income generating for universities in the context of mass production of research and service products. One of the partner villages that needs to be developed is Mitra Senggreng Village, Sumber Pucung, Malang district which has the superior potential of agarwood which is very abundant. So far, agarwood is directly sold in an unprocessed condition, even though after processing the agarwood has a very high selling value. high, in this case the production of tasbih and perfume. Armed with the problems mentioned above, it is necessary to develop a Chopper Machine for Chopping Agarwood integrated with the Smart Gaharu application to make it easier for partner village communities to process agarwood into tasbih and perfume. which focuses on developing the potential of Agarwood wood and becomes a pioneer for future development. In general, the development of this gaharu chopper machine went through 5 stages of the implementation method process, which started from 1) preparation, 2) making the chopper machine, 3) socialization, 4) evaluation, and 5) reporting. The result of this service activity is the development of a Chopper Machine that can effectively be used by gaharu farmers to chop agarwood quickly and easily, the average effectiveness results of 81% obtained from an open questionnaire distributed by farmers through a trial mechanism of 82%, and test results agarwood products by 80%.

Kata kunci—chopper wood, agarwood, pandemic

1. INTRODUCTION

Indonesia is a country that has great regional potential to be developed, according to the 2019 Indonesia Regional Potential Map report (published), there are 320 Leading Potentials that can currently be developed, including porang, bengkoang, red wood, oil palm and agarwood plants. The province that contributes the largest potential for the leading region is the province of East Java, which accounts for 35% of the very large potential of the region. The agricultural sector is the main sector targeted to become the main sector in the next 5 years, this is according to current conditions, in 2022 the Indonesian people have difficulty finding oil because the palm oil sector has failed to harvest, this of course gives a warning to the Indonesian people to continue to increase their superior potential. region as national economic resilience.

Strengthening the superior potential of this region has actually been implemented and analyzed by universities as one of the discourses on strengthening the community economy. cluster 1 also formulates the concept of Partner Village Development (PDM) to formulate and develop regional potentials to regional potentials that are currently developing, the narrowing of this potential is solely to contribute to economic development in regions that are currently untouched by the government, due to the lack of information and there must be MSMEs. which covers the area. This makes farmers in the area directly sell their crops directly to suppliers, even though farmers can process their own crops into products that are more expensive and marketed globally. Senggreng, Sumberpucung, Malang Regency is one of the areas that produces agarwood whose products have been directly sold to suppliers in its entirety, the resulting agarwood actually has a high

selling value when it is in the form of prayer beads or perfume that has high selling value, community empowerment is needed to change the community's mindset towards this agarwood processing. The concept of community empowerment must include the values of the community to build a new paradigm in community empowerment that is people-centered and people-participatory. Efforts to empower the community (empowering people) can be studied from 3 (three) aspects: First, enabling, namely creating an atmosphere that allows the potential of the community to develop. Second, empowering, namely strengthening the potential of the community through concrete steps involving the provision of various inputs and opening up opportunities that will make the community more empowered. The third is protecting, namely protecting and defending the interests of the weak. These three aspects can be realized if there is intervention from the government and the community around the tourism sector.

The concept of Strengthening Partner Villages (PDM) through Cooperation in strengthening regional potential. Through the cooperation of potential village governments and universities, in this case the State University of Malang is one of the main targets to advance areas that have the potential to be developed into productive areas. Dr. Markus Diantoro, said that the partner village collaboration was carried out to encourage each village to make superior thematic products according to the Government's instructions, namely One Product, One Village (Online, accessed February 16, 2022, <http://lp2m.um.ac.id/>) In Figure 1.



Figure 1. Meeting to determine the superior potential of partner villages

Senggreng Sumber Pucung Village, Malang Regency has strong potential to be advanced, in collaboration with LP2M State University of Malang and bound through the Cooperation Agreement for the Implementation of Research and Community Service Number: 3.8.14.UN32.14/KS/2020 has an agreement to be able to increase potential Senggreng village owns the area, especially in the field of agarwood to be used as finished products to improve the economy of partner villages and income generating State University of Malang as a supplier of equipment needed to convert agarwood into beads and perfume products. Mitra Senggreng Village, which is 32 Km from the State University of Malang and has hundreds of agarwood trees, needs to be developed to its full potential, as shown in Figure 2 is a map of Senggreng Village.

2. METHOD

The method of activities carried out in the proposed PDM service is a description in the introduction and solutions to the problems that have been discussed, that the condition of the assisted villages needs to be improved, so several stages in this activity need to be implemented. Broadly speaking, there are 5 stages of the process of implementing the proposed PKM PDM activity method, namely starting from the 1) preparation stage, 2) Chopper machine manufacture, 3) socialization, 4) evaluation, and 5) reporting. The flow of this PKM activity is shown by the flow chart in Figure 2.

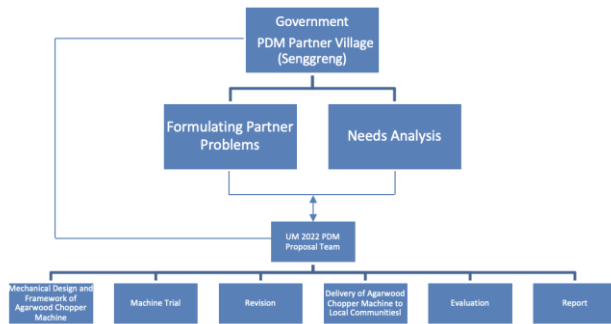

Figure 2. PKM Activity Implementation Flowchart

2.1. Preparation Stage (Problem Analysis and Needs Analysis)

The preparation stage is carried out through 2 conditions, namely the formulation of the partner problem is carried out by field observations by meeting directly with the village head of Senggreng and then an analysis of the needs of the PDM Partner Village at the State University of Malang is compiled. At this stage, all needs are identified in the form of problems proposed by partner villages to design activities. All important information that is available will be recorded and used as material for consideration in implementing community activity programs. At this stage, partners have an important role in providing important information regarding the need for product development of the gaharu chopper machine integrated into the smart gaharu application. After the coordination is complete, the PKM PDM proposal team can carry out a needs analysis and design tools or products related to the development of chopper machines for partner villages.

2.2. Chopper Machine Development Stage

Chopper engine development activities are carried out in stages starting from planning to system revision. Each activity is carried out with an estimated implementation time of approximately 1-2 months. Each activity consists of several stages of making machines, namely (1) designing the engine framework from preparation, design, and purchasing of materials, (2) developing a chopper machine, (3) implementing and testing the gaharu smart application and (4) revising the development of smart gaharu applications. Agarwood if needed. The stages of design, development, and revision are carried out at the State University of Malang, while the stages of implementation and system testing are carried out at the location of the partner village, in this case the village of Senggreng, Sumber Pucung, Malang Regency.

2.3 Stages of Product Use Training

The stages of training on the use of the Agarwood Chopper Machine are carried out after the service product can actually be implemented properly and correctly. This stage was carried out by the proposing team assisted by several undergraduate students of the Department of Electrical Engineering FT UM, while the object of this training was aimed at the community/community/manager/manager appointed from the related partner village. At this stage, it begins with the delivery of products that are ready to be used for later use, then socialized and the last is training. The product submitted, socialized, and made as training material is a chopper machine that is ready to be used along with a machine usage module. The following in Figure 3 is a plan for a chopper machine that is ready for use.

2.4 Stages of Reporting PKM PDM Activities

The preparation of PKM PDM activity reports is carried out at this stage. The writing of the final report begins five months before the final deadline for planning PKM activities. The finalization of the PKM activity reporting takes an estimated time of implementation for approximately one month. The result is that the Implementing Team can complete the PKM PDM report properly and on time along with the achievement of the promised outputs. The report is also accompanied by the name of the supporting component and the component service component guide

3. RESULTS AND DISCUSSION

The development of the Gaharu Chopper Machine that can be used by the surrounding community to chop agarwood to be used as prayer beads and agarwood oil, the development of this chopper machine is integrated with the development of applications that can support the use of the agarwood chopper machine through a helping mechanism for the use and application of the chopper machine as a wood chopper. gaharu, the following in Figure 3 shows the appearance of the gaharu wood chopper machine.

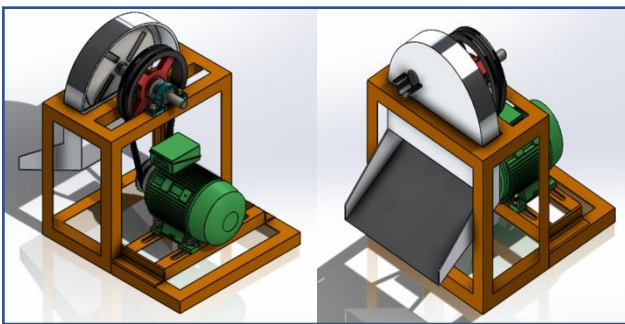

Figure 3. Agarwood Chopper Machine

The development of the agarwood chopper machine uses the concept of a simple blade with a double gear box for gaharu wood chopper, this mechanism of course facilitates the wood chopper process so that the output is smoother, with a large motor and a slimmer blade will produce chopped wood according to the needs of agarwood farmers in implementing akyu agarwood product. Here in Figure 4 is shown the gearbox and blade cutting agarwood.



Figure 4. Gearbox Efficiency and Agarwood Blades

This Agarwood Chopper Machine runs with a high level of security, this is because the agarwood chopper machine was developed with the K3 principle with a cross section of handrails and hand protection from machine injuries, in addition to this because of the use of aluminum e-saf which is famous for being light in use and easy to apply. in daily activities. Details of the minimum requirements for implementing chopper engine development are as follows in Table 1.

Table 1. Chopper Machine Requirements Specification

Type	No	Spesification
Framework	1	Lightweight Aluminum E-Saf
	2	2 millimeter Steel Blade
	3	Grinding Machine
	4	360 degree Swivel Wheel
	5	Agarwood cross section
Cutter	1	Standard Double Blade Steel Cutter
	2	Counter Bar 2 Branches or. Wood
	3	Backup Bar
Machine Role Handle	1	Cross-section of Handrails
	2	hand protection

These specifications are related to the application of the gaharu wood chopper machine as a whole in community service activities. The concept of the specification is, of course, designed to facilitate the use of the Agarwood Chopper Machine so that it is easy to use in its entirety by agarwood farmers, through sustainable use, the chopper machine can be used maximally in cutting and chopping agarwood. Tests were also carried out to see the level of capability required on the chopper machine, through feasibility tests and product yield tests. The results of the feasibility test, yielded valid results, this was obtained from the success rate on the feasibility of reaching 82%, which was taken from 20 gaharu farmer respondents through an open questionnaire after socializing the use of gaharu chopper tools. The production test also gets a maximum result of 80% of the quality of the chopped products taken from 20 respondents randomly. The following table 2 details the results of the feasibility test on the agarwood chopper machine.

Tabel 2. Agarwood chopper machine feasibility test

Type Test	Total Question	Results	Successfully(%)
Feasibility test	20	Valid	82%
Product Test result	20	Valid	80%
Average Total			81%

4. CONCLUSION

The development of the Agarwood Chopper Machine in this community service activity is to increase the business activities of the Senggreng community by giving. Alternatives and solutions to the processing of agarwood which is one of the livelihoods of the community around Senggreng village. The results of the feasibility test, yielded valid results, this was obtained from the success rate on the feasibility of reaching 82%, which was taken from 20 gaharu farmer respondents through an open questionnaire after socializing the use of gaharu chopper tools. The production test also gets a maximum result of 80% of the quality of the

chopped product taken from 20 respondents randomly. The development of this agarwood chopper machine also involves the community in taking needs and analyzing the needs of the chopper machine through FGD which was carried out with the Senggreng village community, with this collaboration concept development is easier and more integrated with the community's needs for this service activity and of course it will make it easier for agarwood farmers. himself to directly develop the agarwood chopper machine.

ACKNOWLEDGEMENT

The authors would like to thank LP2M State University of Malang which has funded the Non-State Budget Service Grant (Internal Fund) with Rector Decree Number 18.5.59/UN32/KP/2022, as well as the Department of Electrical Engineering, Faculty of Engineering which has provided support and equipment to develop Gaharu Chopper Machine in this service activity.

REFERENCES

- [1] Andasuryani., Santosa., Chandra, Alhapen Ruslin. 2009. Membangun Mesin Pencacah Rumput Gajah Untuk Peningkatan Efektivitas Konsumsi Pakan Ternak Sapi. Artikel Ilmiah Pelaksanaan Program Pengabdian Program Vucer Tahun 2009
- [2] Aji, Dhanar Yuwono. 2013. Desain Generator Axial Kecepatan Rendah Dengan Menggunakan Magnet Permanen. Skripsi,. Surakarta: Universitas Muhammadiyah Surakarta
- [3] Azwin, Rahmat.2013, Reverse Engineering dan Re-Engineering sebagai solusi pemeliharaan pembangkit.Info PJB, Eisi 84/November. Hal 3-5
- [4] Bagci, E., 2009, Reverse Engineering Applications for Recovery of Broken or Worn Parts and Re-Manufacturing: three Case Studies, Journal of Advances in Engineering Software. Vol. 40 Issue 6, pp. 407-418.
- [5] Batubara ,Helmina. 2013. Penentuan Harga Pokok Produksi Berdasarkan Metode Full Costing Padanpembuatan Etalase Kaca Dan Alumunium Di Ud. Istana Alumunium Manado. Jurnal Emba. Vol.1 No.3 September 2013, Hal. 217- 224
- [6] Bimo ,Ardi Bawono., Santoso, Hari., dan Soemarwanto. 2007. Rancang Bangun Automatic Transfer Switch Pada Motor Bensin Generator-Set 1 Fasa 2,8 Kw 220 Volt 50 Hertz. Jurnal Eeccis Vol. 1, No. 1, Juni 2007
- [7] Burston, M.T., Sabatini, R., Clothier, R., Gardi, A., dan Ramasamy, S. 2014. "Reverse Engineering of a Fixed Wing Unmanned Aircraft 6-DoF Model for Navigation and Guidance Applications", Applied Mechanics and Materials, vol. 629, pp. 164-169, Trans Tech Publications, 2014. DOI: 10.4028/www.scientific.net/AMM.629.164
- [8] Corbo, p., Germani M., Mandorli F. 2004, Aesthetic And Functinal Analysis for Product Model Validation in Reverse Engineering Application, Computer Aided Design, 36, pp 65-74.
- [9] DITJENAK., 2006. Kebutuhan Susu DiIndonesia,Impor Susu Untuk Memenuhi Kebutuhan Susu Indonesia.
- [10] Febriantoko, Bambang Waluyo. 2012.Reverse Engineering Sebagai Basis Desain Pengermbangan Mobil Mini Truck Esemka. Prosiding Semminar Nasional Aplikasi Sains & Teknologi (SNAST) periode III. Yogyakarta: 3 November 2012

-
- [11] Kumar A., Jain, P. K. & Pathak, P. M. 2013. Reverse Engineering In Product Manufacturing: An Overview. Dalam International Scientific Book 2013 Pp. 665-678 Chapter 39
- [12] Lasena , Sitty Rahmi. 2013. Analisis Penentuan Harga Pokok Produksi Pada Pt. Dimembe Nyiur Agripro. Jurnal Emba 585.Vol.1 No.3 Juni 2013, Hal. 585- 592
- [13] Panchhetti M., Pernot J.P., Veron P.,2010, Towards Recovery of Complex Sapes in Meshes Using Digital Images for Reverse Engineering Aplication, Cumputer Aided Design, 42, pp 693-707
- [14] Raja, V. 2008. Reverse Engineering, Springer Verlag London.
- [15] Shanghai MAC Company. 2013. Jenis – enis Mesin Pencacah Rumput Ternak Sapi. Diakses Pada Tanggal 31 Mei 2016 Didapatkan dari http://www.idpenghancur.com/mill/n_4300.html
- [16] Slat, Andre Henri. 2013. Analisis Harga Pokok Produk Dengan Metode Full Costing Dan Penentuan Harga Jual. Jurnal Emba. Vol.1 No.3 Juni 2013, Hal. 110-117
- [17] Sulistyono. 2015. Perancangan Desain Gitar Elektrik Senar 8 (Ts-8) Dengan Kombinasi Perangkat Smartphone Sebagai Virtual Efek Gitar Menggunakan Metode Reverse Engineering. Skripsi,. Surakarta: Universitas Muhammadiyah Surakarta.